

JUKI®

No.0014-13

1983・3

BE5550SOPJA

model **DDL-555** サブクラス
& SUBCLASSES

高速一本針本縫ミシン

High Speed Single Needle Lockstitch
Industrial Sewing Machine

PARTS BOOK

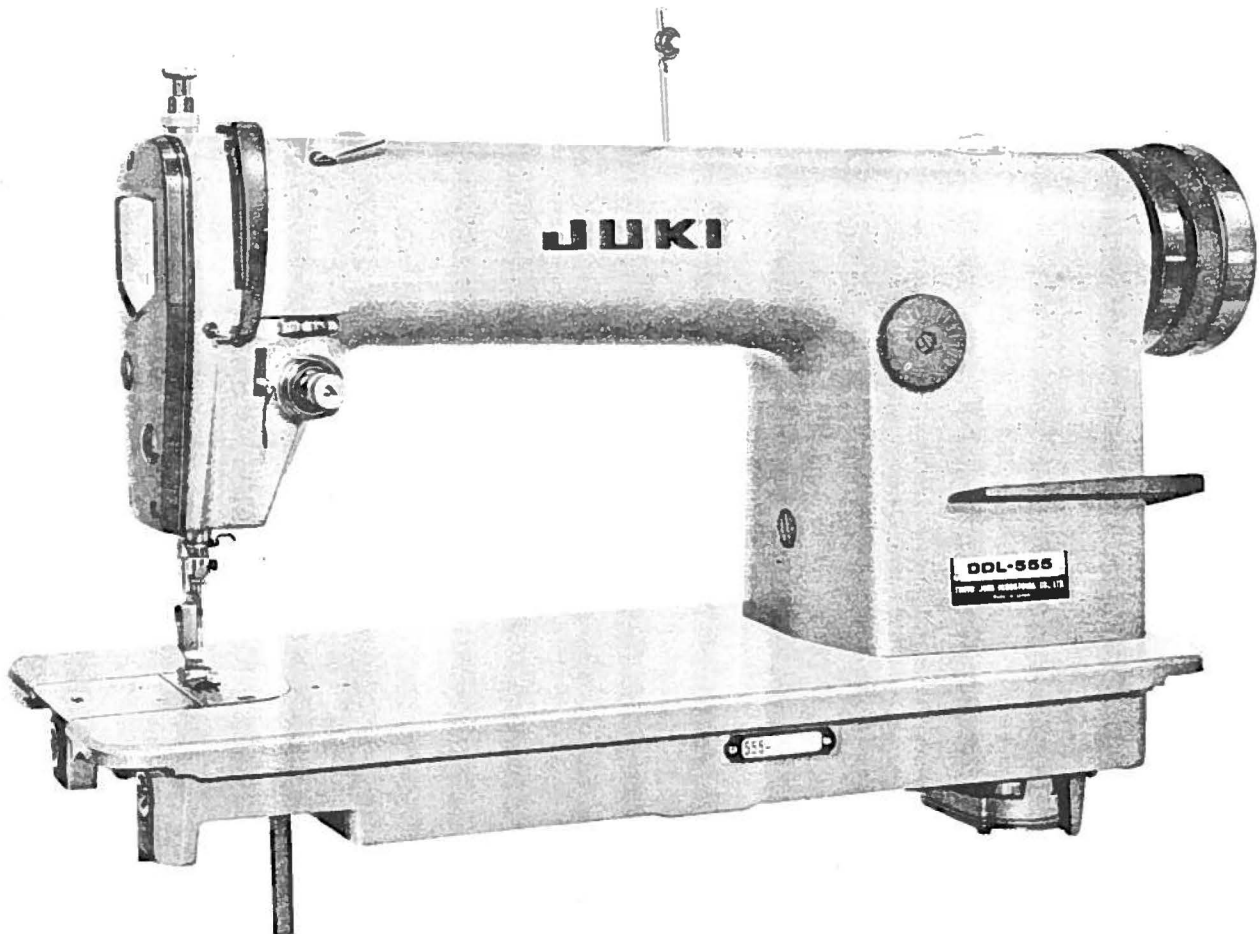

TOKYO JUKI INDUSTRIAL CO., LTD.

From the library of: Superior Sewing Machine & Supply LLC

HOW TO MAKE USE OF THIS PARTS BOOK

- As a basic principle, this parts book is divided into various sections according to the functions of respective parts.
- The part numbers of parts shown in the figure indicate the corresponding numbers(Ref.No.) shown by the Index.

3. Explanation of codes

- ① ☆ mark means this part is changed from the previous parts book.
- ② ○01..... refer to "Note" explanation at bottom of page.
- Codes on the "E.C. (Engineering change)" column
 - ① A.10/74 Added from October, 1974
 - ② D.1/75..... Obsolete from January, 1975
 - ③ When D.(obsolete) and A.(added) are indicated together
D.12/74
A.12/74
- ④ When previous parts (Obsolete part) and new parts (Added parts) are not interchangeable with each other:
In this case, even obsolete parts(D.) can be ordered with the obsolete part number, so select the parts with changed dates and place your orders.

(Example)

Ref. No.	Note	Part No.	Description	E.C.	品名	Amt. Req.
	注記	品番		変更年月		数量
1	☆	B1401-100-000	Needle bar	D.12/74	ハリボー	—
1-1	☆	B1401-100-000-A	Needle bar	A.12/74	ハリボー	1

- ⑤ In case when previous parts and new part are interchangeable with each other:
In this case the new part number is replaced on the "品名(Japanese)" column of the previous parts, so please order by the new part number.

(Example)

Ref. No.	Note	Part No.	Description	E.C.	品名	Amt. Req.
	注記	品番		変更年月		数量
1	☆	B1105-200-000	Frame cover	D.12/74	B1105-300-000	—
	☆	B1105-300-000	Frame cover	A.12/74	フレームカバー	1

- ④ C.3/75 This indicates error was discovered in March, 1975 and so it was corrected to a new part number.
Please note that in this case, the corrected part number is shown in the part number column and the wrong part number is shown in the "品名(Japanese)" column, so please order by the correct part number.

(Example)

Ref. No.	Note	Part No.	Description	E.C.	品名	Amt. Req.
	注記	品番		変更年月		数量
1	☆	B1105-500-000	Frame cover	C.3/75	B1105-600-000	1
		↑ Correct No.			↑ Wrong No.	

- ⑤ M.5/75 The amount required is changed from March, 1975
The new amount required is shown in the "Amt. Req." column.

3) Codes on the "Amt. Req." column

- ① 2 Indicates amount required is 2.
- ② 2.0 Indicates length in meters. (unit is meter)
- ③ — Indicates parts obsolete from the parts book.
- ④ (1)..... Indicates sub parts which construct the assembly part.
Assembly part is shown as "asm." and クミ in Japanese, in the "Description" column.

(Example)

Ref. No.	Note	Part No.	Description	E.C.	品名	Amt. Req.
	注記	品番		変更年月		数量
10		B1105-900-0A0	Frame cover asm.		フレームカバー クミ	1
11		B1105-900-000	Frame cover		フレームカバー	(1)
12		SS-8110310-SP	Screw 11/64-40 L=2.8		トメネジ 11/64-40 L=2.8	(2)

When Ordering The Spare Parts:

In order to ensure that we deliver the correct parts to you, please clearly state when ordering the corresponding PART NUMBER (e.g. B1109-012-A00) and also the PARTS BOOK NUMBER (e.g. 0010-01, given at the top right of the cover) or the MACHINE SERIAL NUMBER, because there are some parts which have been changed.

パーツブックの見方

- このパーツブックは、原則として、機構別に分類された各項目からなっております。
- 図に示された部品の品番は、図にふられている No.(Ref. No.) に対応するインデックスによって、その品番がわかります。
- 記号の説明

1) "注記" 欄の記号

- ☆印……………前回のパーツブックと比較して今回変更された部品を意味します。
- ◇印……………ページ下の"注記"の説明を参照して下さい。

2) "変更年月" 欄の記号

- A. 10/74……………1974年10月より追加された。
- D. 1/75……………1975年1月より削除された。
- D. (削除)、A. (追加) が連記してある場合。
D. 12/74
A. 12/74

③ 部品の互換性がない変更の場合

この場合は削除(D)された品番でも御注文できますから、変更年月により、いずれかの部品を選択して御注文下さい。

[例]

Ref. No.	Note	Part No.	Description	E.C.	Amt. Req. 数量
	注記	品番		変更年月	品名
1	☆	B1401-100-000	Needle bar	D.12/74	ハリポー
1-1	☆	B1401-100-000-A	Needle bar	A.12/74	ハリポー

④ 部品の互換性がある場合の変更

この場合は、旧部品の和文品名欄にそれにかわる新しい品番が記入してありますので、新しい品番で御注文下さい。

[例]

Ref. No.	Note	Part No.	Description	E.C.	Amt. Req. 数量
	注記	品番		変更年月	品名
1	☆	B1105-200-000	Frame cover	D.12/74	B1105-300-000
	☆	B1105-300-000	Frame cover	A.12/74	フレームカバー

④ C. 3/75……………1975年3月に品番のミスが判明した為、正しい品番に訂正された。

この場合は品番欄に正しい品番を、和文品名欄に間違いの品番が記入してありますので、正しい品番で御注文下さい。

[例]

Ref. No.	Note	Part No.	Description	E.C.	Amt. Req. 数量
	注記	品番		変更年月	品名
1	☆	B1105-500-000	Frame cover	C.3/75	B1105-600-000
		↑ 正しい品番			↑ 間違っていた品番

⑤ M. 5/75……………1975年5月より数量が変更になった。

この場合数量欄には新しい数量が表示してあります。

3) "数量" 欄の記号

- 2……………数量、2個を表わします。
- 2.0……………長さ、2メートルを表わします。(単位はメートルです)
- ……………このパーツブックから削除された部品です。
- (1)……………組部品を構成している子部品を表わします。
組部品は品名欄に英文で "asm." 和文で "クミ" と表示してあります。

[例]

Ref. No.	Note	Part No.	Description	E.C.	Amt. Req. 数量
	注記	品番		変更年月	品名
10		B1105-900-0A0	Frame cover <u>asm.</u>		フレームカバー <u>クミ</u>
11		B1105-900-000	Frame cover		フレームカバー
12		SS-8110310-SP	Screw 11/64-40 L=2.8		トメネジ 11/64-40 L=2.8

補用部品注文の際の御注意

このパーツブックに記載されている補用部品を御注文の際は、部品の番号(例えば、B1109-012-A00)で御注文下さい。合わせて、御覧のパーツブックの管理番号(表紙右上、例えば、No. 0010-01)又は、機械番号を御連絡頂ければ幸いです。

改良のため部品の一部が変更になる場合がありますのでご了承下さい。

CONTENTS

目次

1. FRAME & MISCELLANEOUS COVER COMPONENTS	
頭部・外装関係	1
2. MAIN SHAFT & UPRIGHT SHAFT & NEEDLE BAR COMPONENTS	
上軸・立軸・針棒関係	3
3. HOOK DRIVING SHAFT & PRESSER BAR & KNEE LIFTER COMPONENTS	
下軸・押エ棒・膝上げ関係	5
4. FEED MECHANISM COMPONENTS (1)	
送り関係 (1)	7
5. FEED MECHANISM COMPONENTS (2)	
送り関係 (2)	9
6. LUBRICATION COMPONENTS	
給油関係	11
7. OIL RESERVOIR & KNEE LIFTER COMPONENTS	
油溜・膝上げ関係	12
EXCLUSIVE PARTS LIST OF DDL-555 SUBCLASS SEWING MACHINES	
DDL-555 サブクラス専用部品一覧表	13
8. EXCLUSIVE PARTS FOR SUBCLASS COMPONENTS	
サブクラス専用部品	
1. DDL-555-A	13
2. DDL-555-W	14
3. DDL-555-H	14
9. SPECIAL ORDER PARTS	
特別注文部品	15
10. NUMERICAL INDEX OF PARTS	
索引	16

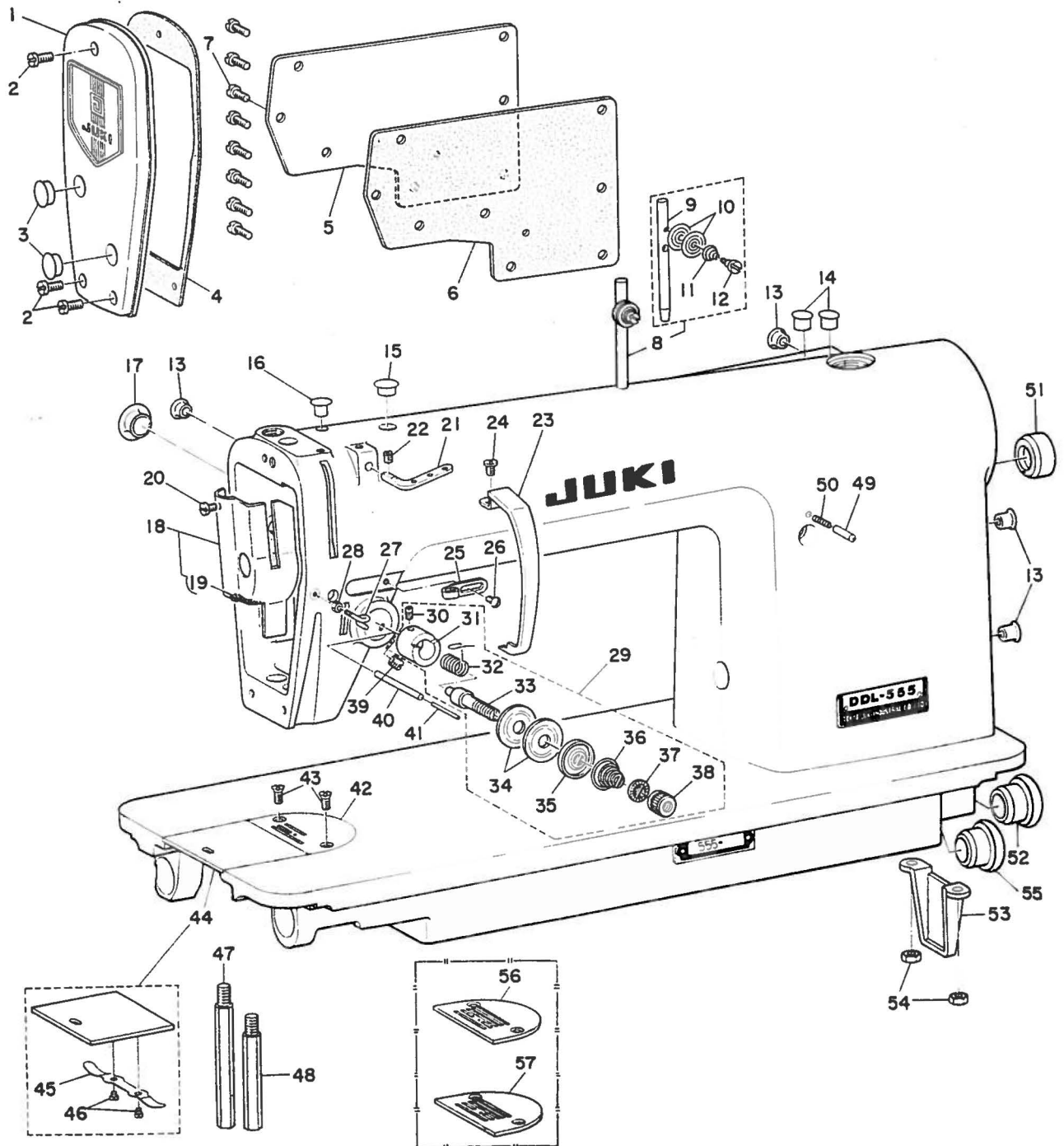

Ref. No.	Note	Part No.	Description	E.C.	品名	Amt. Req.
	注記	品番		変更年月		数量
1		B1121-552-0A0	Face plate asm.		面板 (組)	1
2		SS-7111120-SP	Screw 11/64-40 L=10.5		面板止メネジ	3
3		B1179-552-000	Rubber plug	D.10/79	TA-1250406-R0	-
		TA-1250406-R0	Rubber plug	A.10/79	面板調節ネジ穴キャップ	2
4		B1122-552-000	Gasket		面板パッキン	1
5		B1118-522-000	Side plate		窓板	1
6		B1119-522-000	Gasket		窓板パッキン	1
7		SS-7110910-SP	Screw 11/64-40 L=8.5		窓板止メネジ	8
8	◆01	B1113-155-0A0	Needle thread guide pin asm.		糸案内棒 (組)	1
9	◆01	B1113-155-000	Needle thread guide pin		糸案内棒	(1)
10	◆01	B3148-123-000	Tension disc		糸案内棒皿	(2)
11	◆01	B3149-123-A00	Spring		糸案内棒皿バネ	(1)
12	◆01	SD-0380552-SL	Stud D=3.8 H=5.5		糸案内棒皿軸	(1)
13		B1117-552-000	Rubber plug	D.10/79	TA-0800704-R0	-
		TA-0800704-R0	Rubber plug	D.2/81	TA-0750704-R0	-
		TA-0750704-R0	Rubber plug	A.2/81	メタル止ネジ穴キャップ	4
14		B1186-552-000	Rubber plug	D.10/79	上下送りロッド穴キャップ	-
15		B1187-552-000	Rubber plug	D.10/79	TA-1050504-R0	-
		TA-1050504-R0	Rubber plug	A.10/79	上軸メタル油心穴キャップ	1
16		B1117-552-000	Rubber plug	D.10/79	TA-0800704-R0	-
		TA-0800704-R0	Rubber plug	D.2/81	TA-0750704-R0	-
		TA-0750704-R0	Rubber plug	A.2/81	天ビンランク軸止ネジ穴止栓	1
17		B1164-012-000	Counterweight screw hole plug	D.10/79	TA-1250705-R0	-
		TA-1250705-R0	Rubber plug	A.10/79	釣合鍾止ネジ穴キャップ	1
18		B1188-552-0A0	Arm oil shield asm.		面部油防板 (組)	1
19		CQ-2020000-00	Oil wick		面部油防板油心	(0.1)
20	◆01	SS-6080410-SP	Screw 1/8=44 L=4.0		面部油防板止メネジ	1
21		B1128-522-000	Three-hole thread eyelet		三ツ目糸掛ケ	1
22		SS-8110510-SP	Screw 11/64-40 L=5.0		三ツ目糸掛ケ止メネジ	1
23		B1123-552-000-A	Thread take-up lever cover		天ビンカバー	1
24		SS-7110510-SP	Screw 11/64-40 L=5.0		天ビンカバー止メネジ	1
25	◆01	B1126-552-000	Frame thread guide (A)		アーム糸案内 (A)	1
26		SS-5090610-SP	Screw 9/64-40 L=3.5		アーム糸案内 (A) 止メネジ	1
27		B3114-761-000	Frame thread guide (B)		アーム糸案内 (B)	1
28		NS-6060350-SP	Nut 3/32-56		アーム糸案内 (B) 止メナット	1
29		B3111-552-0A0	Tension controller asm.		糸調子 (組)	1
30		SS-8090670-SP	Screw 9/64-40 L=5.5		糸調子棒止メネジ	(1)
31	◆01	B3111-552-B00	Thread tension post socket		糸調子棒台	(1)
32	◆01	B3128-012-000	Take-up spring		糸取りバネ	(1)
33		B3115-552-000	Thread tension post		糸調子棒	(1)
34		B3126-012-000	Thread tension disc		糸調子皿	(2)
35		B3132-552-000	Presser		糸調子皿押エ	(1)
36	◆01	B3129-012-A00	Thread tension spring		糸調子バネ	(1)
37		B3120-125-000	Thread disc rotation stopper		糸調子皿回転止	(1)
38		B3*16-125-000	Thread tension nut		糸調子ナット	(1)
39		SS-8150710-SP	Clamp screw 15/64-28 L=7.0		糸調子棒台締メネジ	1
40		B3127-127-000	Tension release auxiliary pin		糸ユルメ補助ピン	1
41		B3118-552-C00	Tension release pin		糸ユルメピン	1
42	◆01	B1109-012-A00	Throat plate (A)		針板 (A)	1
43		SS-2110920-TP	Screw 11/64-40 L=8.5		針板止メネジ	2
44		B1110-012-0A0	Bed slide asm.		滑り板 (組)	1
45		B1111-012-000	Spring		滑り板バネ	(1)
46		SS-6060210-SP	Screw 3/32-56 L=1.9		滑り板バネ止メネジ	(2)
47		B1104-122-000	Bed screw stud (A)		ベット支柱 (A)	1
48		B1105-122-000	Bed screw stud (B)		ベット支柱 (B)	1
49		B1147-555-000	Feed regulator pin		送り調節ピン	1
50		B1148-555-000	Spring		送り調節ピンバネ	1
51		B1189-415-000	Rubber plug	D.10/79	TA-2101002-R0	-
		TA-2101002-R0	Rubber plug	A.10/79	調節器穴キャップ	1
52		B1166-552-000-A	Hook shaft rubber plug	D.10/79	TA-2351004-R0	-
		TA-2351004-R0	Rubber plug	A.10/79	下軸盲フタ	1
53		B1106-122-000	Bed support		ベット支持板	1
54		NS-6150310-SP	Nut 15/64-28		ベット支持板ナット	2
55		B1166-552-000-A	Rubber plug	D.10/79	TA-2351004-R0	-
		TA-2351004-R0	Rubber plug	A.10/79	上下送り軸穴キャップ	1
56	◆01	B1109-555-G00	Throat plate (G)	A.7/75	針板 (G)	1
57	◆01	B1109-555-J00	Throat plate (J)	A.8/77	針板 (J)	1

Note (注記) ◆01 When these parts are to be used for subclass machines of DDL-555, please refer to the exclusive subclass list of DDL-555. (Page 13)

サブクラスミシン使用の場合、サブクラス専用部品一覧表を参照してください。(13ページ)

◆01 Special order part 特別注文部品

From the library of: Superior Sewing Machine & Supply LLC

UPRIGHT SHAFT & NEEDLE BAR COMPONENTS

上軸・立軸・金

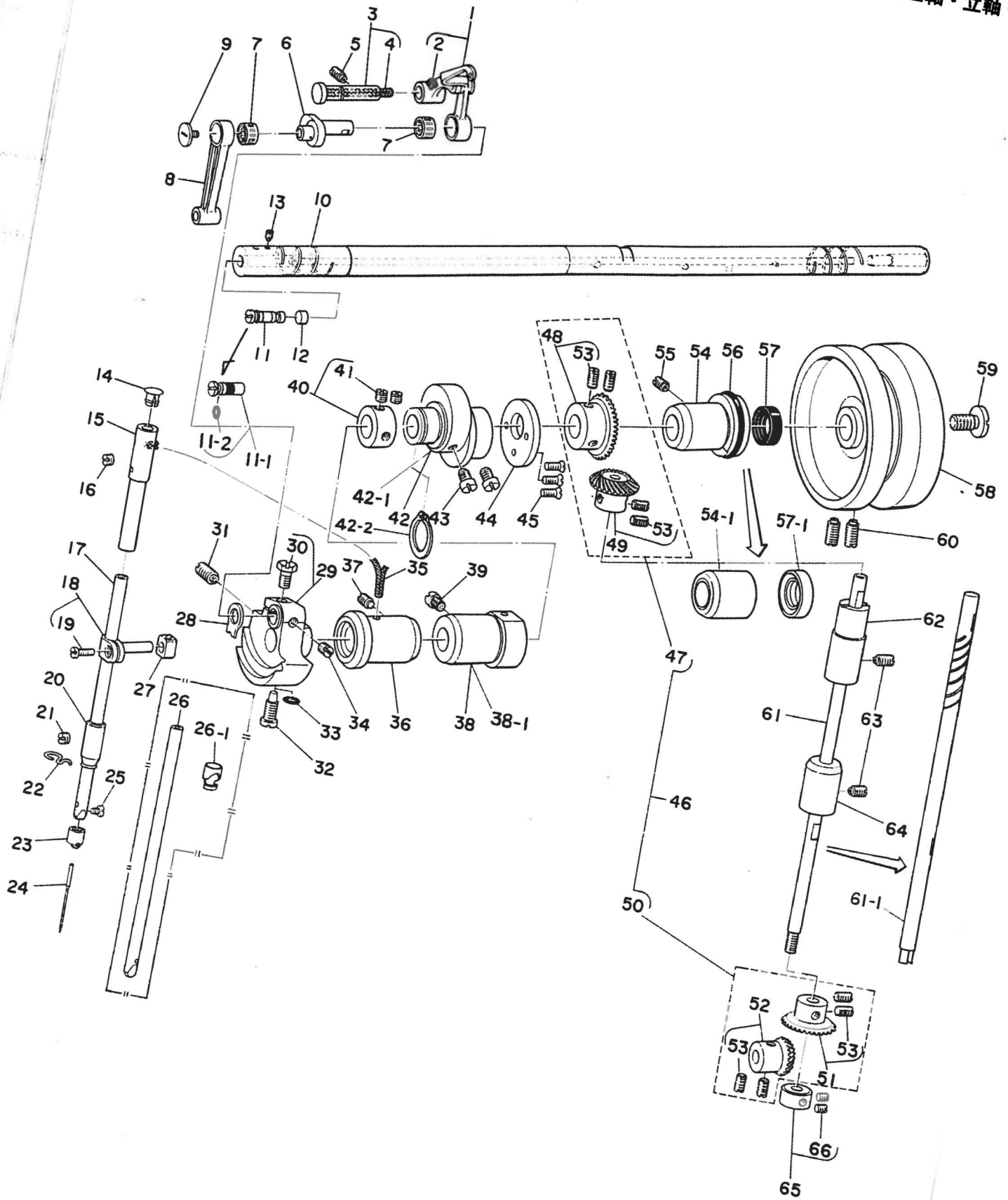

2. MAIN SHAFT & UPRIGHT SHAFT & NEEDLE BAR COMPONENTS

上軸・立軸・針棒関係

Ref. No.	Note	Part No.	Description	E.C.	品名	Amount
	注記	品番		変更年月		数量
1		B1901-552-0C0	Thread take-up lever asm.		リンク天ヒン (組)	1
2		CQ-2000000-00	Oil wick		リンク天ヒン油心	(0.1)
3		B1904-552-0A0	Thread take-up crank shaft stud asm.		天ヒンクラック軸 (組)	1
4		CQ-2020000-00	Oil wick		天ヒンクラック軸油心	(0.2)
5		SS-8151150-SP	Screw 15/64-28 L=10.5		天ヒンクラック軸止メネジ	1
6	*01	B1209-552-000	Needle crank		針棒クラック	1
7		B1905-541-800	Needle shaft bushing		天ヒンニードル軸受	2
8		B1408-552-000	Needle bar crank rod		針棒クラックロッド	1
9		B1903-552-000	Thread take-up crank screw, left		天ヒンクラック左ネジ	1
10		B1201-555-000	Main shaft		上軸	1
11		B1213-552-0A0	Crank oil adjusting pin asm.	D 2/80	クラック油量調節ピン	1
11-1		B1213-552-0A0-A	Oil adjusting pin asm.	A.2/80	クラック油量調節ピン (組)	1
11-2		RO-0291801-00	Rubber ring	A 2/80	Oリング	1
12		B1226-552-000	Oil regulating felt		クラック油量制限フェルト	1
13		B1224-552-000	Screw	D.2/80	クラック油量調節ピン止メネジ	1
14		B1405-012-000	Rubber plug		針棒上メタルフタ	1
15		B1402-552-000-A	Needle bar bushing, upper		針棒上メタル	1
16		SS-8150310-SP	Screw 15/64-28 L=3.4		針棒上メタル止メネジ	1
17	*01	B1401-552-A00	Needle bar (A)		針棒 (A)	1
18		B1411-552-0A0	Needle bar connection asm.		針棒抱キ (組)	1
19		SS-6090670-TP	Clamp screw 9/64-40 L=6.0		針棒抱キ締メネジ	(1)
20	*01	B1403-155-000	Needle bar bushing, lower		針棒下メタル	1
21		SS-8150310-SP	Screw 15/64-28 L=3.4	D 4/78	針棒下メタル止メネジ	1
22	*01	B1419-155-000	Needle bar thread guide		針棒糸案内	1
23	*01	B1418-541-000	Needle bar thread guide	D.11/81	B1418-552-A00	1
	*01	B1418-552-A00	Needle bar thread guide	A.11/81	針棒糸掛	1
24	*01	MDB-100B1400	Needle (DBx1, #14)		針 (DB・I=14)	1
25		SS-7080510-SP	Screw 1/8-44 L=3.4	D.6/80	SS-7080510-T-P	1
		SS-7080510-TP	Screw 1/8-44 L=3.4	A.6/80	針止メネジ	1
26	*01	B1401-552-800	Needle bar (B)		針棒 (B)	1
26-1	*01	B1418-541-000	Needle bar thread guide	A.11/81	針棒糸掛ケ	1
27		B1414-232-000	Needle bar guide block	D.6/82	B1414-555-000	1
		B1414-555-000	Needle bar guide block	A.6/82	針棒抱キ案内コロ	1
28		B1212-552-A00	Counterweight wearing plate (A)		釣合鐘保護板 (A)	1
29	*01	B1206-552-0A0	Counterweight asm.		釣合鐘 (組)	1
30	*01	SS-9661120-CP	Clamp screw 1/4-40 L=10.5		針棒クラック締メネジ	1
31		SS-8681950-SP	Screw (B) 9/32-28 L=19.0		釣合鐘止メネジ (B)	1
32		SS-7681650-TP	Screw (A) 9/32-28 L=19.0		釣合鐘止メネジ (A)	1
33		RO-0442401-00	Rubber ring		釣合鐘止メネジOリング	1
34		SS-8660610-TP	Screw 1/4-40 L=6.0		針棒クラック止メネジ	1
35		CQ-2020000-00	Oil wick	D.7/82	針棒給油油心	1
36		B1202-552-800-A	Main shaft bushing, front		上軸前メタル	1
37		SS-8151150-SP	Screw 15/64-28 L=10.5		上軸前メタル止メネジ	1
38		B1203-227-000	Main shaft bushing, intermediate	D 11/79	上軸中メタル	1
38-1		B1203-227-000-A	Main shaft bushing, intermediate	A.11/79	上軸中メタル	1
39		SS-7151120-SP	Screw 15/64-28 L=11.0		上軸中メタル止メネジ	1
40		CS-147121A-SH	Main shaft thrust collar asm.		上軸スラスト受け (組)	1
41		SS-8660610-TP	Screw 1/4-40 L=6.0		上軸スラスト受け止メネジ	(2)
42	*01	B1610-555-000	Feed drive eccentric cam	D 4 80	送り偏心カム	1
42-1		B1610-555-000-A	Feed drive eccentric cam	A 4 80	送り偏心カム	1
42-2		RC-1850001-KP	Snap ring	A 4 80	上下送りロッド止メ輪	1
43		SS-6661110-SP	Screw 1/4-40 L=11.0		送り偏心カム止メネジ	2
44		B1611-161-000	Feed eccentric thrust washer		送りカムスラスト受け	1
45		SS-2110930-SP	Screw 11/64-40 L=8.7		送りカムスラスト受け止メネジ	3
46		B1306-155-0C0	Gear & pinion asm.		カサ歯車 (上下組)	1
47		B1306-155-0B0	Gear & pinion asm., upper		上カサ歯車 (組)	(1)
48		B1305-012-0A0	Gear asm.		上カサ歯車 (大) (組)	(1)
49		B1306-155-0A0	Pinion asm.		上カサ歯車 (小) (組)	(1)
50		B1307-155-0B0	Gear & pinion asm., lower		下カサ歯車 (組)	(1)
51		B1307-155-0A0	Gear asm.		下カサ歯車 (大) (組)	(1)
52		B1308-155-0A0	Pinion asm.		下カサ歯車 (小) (組)	(1)
53		SS-8660810-TP	Screw 1/4-40 L=8.0		歯車止メネジ	(8)
54		B1204-552-800	Main shaft bushing, rear	D 9 80	上軸後メタル	1
54-1		D1204-555-D0B	Main shaft bushing, rear	A 9 80	上軸後メタル	5
55		SS-8151150-SP	Screw 15/64-28 L=10.5		上軸後メタル止メネジ	1
56		RO-2943101-00	Rubber ring	D 9 80	上軸後メタルOリング	1
57		B1208-552-000-A	Oil seal ring	D 9 80	上軸後メタルオイルシール	1
57-1		D1208-555-D00	Oil seal ring	A 9 80	上軸後メタルオイルシール	1
58		B1217-555-000	Hand wheel		ハズミ車	1
59		B1233-012-000	End screw	D 4 79	SS-7701010-SP	1
		SS-7701010-SP	End screw	A 4 79	ハズミ車押シ上ケネジ	1
60		SS-8151550-SP	Screw 15/64-28 L=15.0		ハズミ車止メネジ	2
61		B1301-552-000	Upright shaft	D 8 80	立軸	1
61-1		B1301-555-000	Upright shaft	A 8 80	立軸	1
62		B1302-552-800	Bushing, upper		立軸上メタル	1
63		SS-8151150-SP	Screw 15/64-28 L=10.5		立軸上メタル止メネジ	2
64		B1303-552-800	Bushing, lower		立軸下メタル	1
65		CS-0791010-SH	Thrust collar asm.	D.1/79	立軸スラスト受け (組)	1
66		SS-8110520-TP	Screw 11/64-40 L=4.5	D.1/79	立軸スラスト受け止メネジ	1

Note (注記) *01 Special order part

*01 When these parts are to be used for subclass machines of DDL-555, please refer to the exclusive subclass list of DDL-555. (Page 13)

特別注文部品

サブクラスマシン使用の場合、サブクラス専用部品一覧表を参照してください。(13ページ)

3. HOOK DRIVING SHAFT & PRESSER BAR & KNEE LIFTER COMPONENTS

下軸・押工棒・膝上ゲ関係

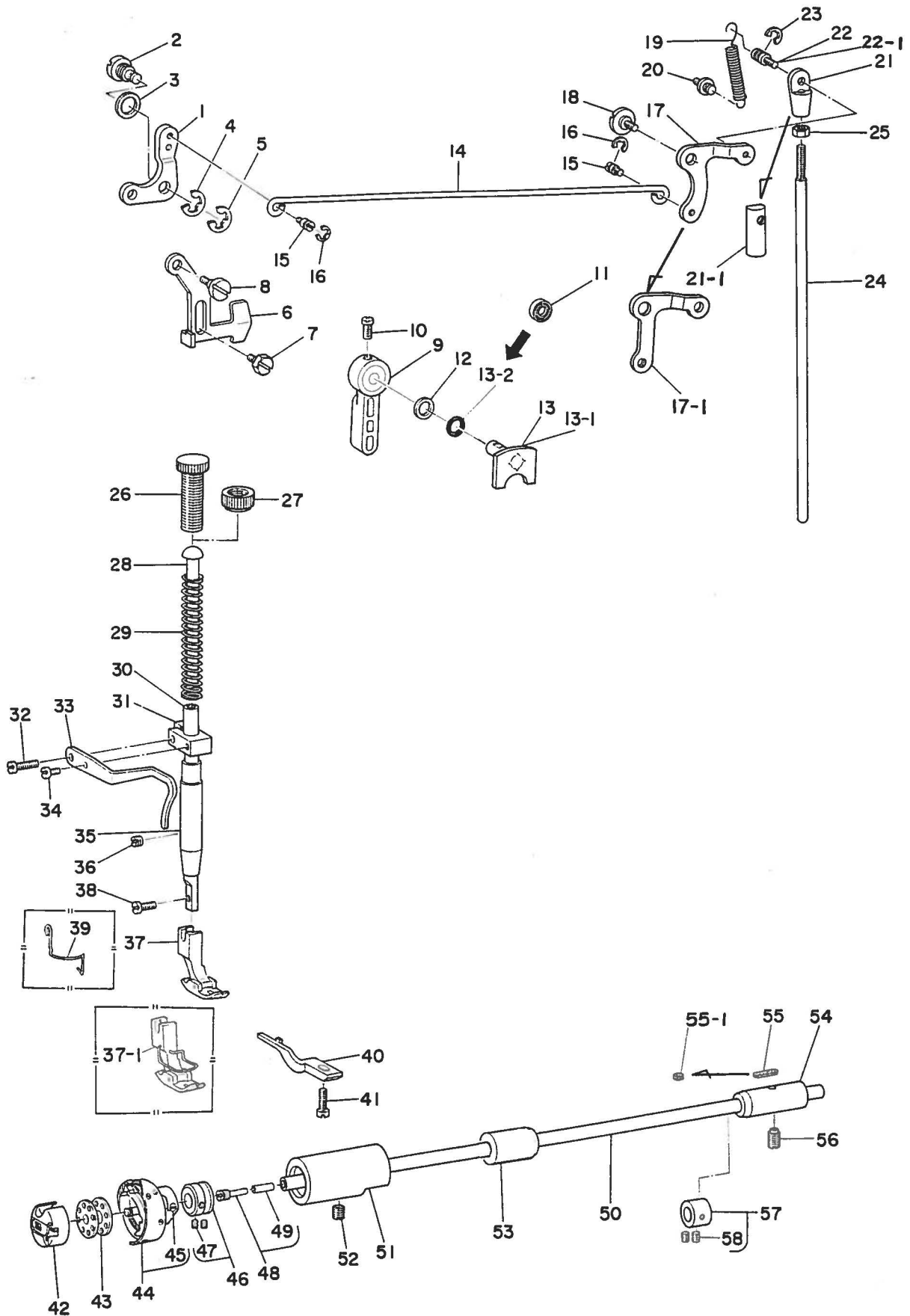

3. HOOK DRIVING SHAFT & PRESSER BAR & KNEE LIFTER COMPONENTS

下軸・押工棒・ヒザ上げ関係

Ref. No.	Note	Part No.	Description	E.C.	品名	Amt. Req. 数量
	注記	品番		変更年月		
1		B1516-552-000	Lifting lever link		引キ上げ板リンク	1
2		B1517-552-000	Shaft		引キ上げ板リンク軸	1
3		B3431-581-000	Gasket		引キ上げ板リンク軸パッキン	1
4		RE-0600000-KO	Snap ring		引キ上げ板リンク軸止メ環	1
5		B1523-226-000	Snap ring (B)		引キ上げ板リンク軸止メ環 (B)	1
6		B1515-552-000	Lifting lever		引キ上げ板	1
7		SD-0630275-SP	Hinge screw (A) D=6.35 H=2.7		引キ上げ板段ネジ (A)	1
8		SD-0630301-SP	Hinge screw (B) D=6.35 H=3.0		引キ上げ板段ネジ (B)	1
9		B1520-552-000	Hand lifter lever		押エ上ゲレバー	1
10		SS-7120910-SP	Screw 3/16-28 L=9.0		押エ上ゲレバー止メネジ	1
11		B1522-552-000	Oil seal	D.11/76	押エ上ゲ軸オイルシール	—
12		WP-0740516-SP	Washer 7.4x11.8x0.5		押エ上ゲ軸座金	1
13	001	B1518-552-0A0	Hand lifter cam asm.	D.11/76	押エ上ゲカム (組)	—
13-1		B1518-481-0A0	Hand lifter cam asm.	A.11/76	押エ上ゲカム (組)	1
13-2		RO-0371801-00	O ring	A.11/76	押エ上ゲカムOリング	1
14		B3412-552-000	Lifting lever connecting rod		ヒザ上げ横棒	1
15		B3416-552-000	Hinge screw		ヒザ上げ横棒段ネジ	2
16		RE-0500000-KO	Spring		ヒザ上げ横棒止メ環	2
17		B3414-552-000	Lifting lever link arm	D.4/79	ヒザ上ゲリンク腕	—
17-1		B3414-555-000	Lifting lever link arm	A.4/79	ヒザ上ゲリンク腕	1
18		SD-0720331-SP	Hinge screw D=7.24 H=3.3		ヒザ上ゲリンク腕段ネジ	1
19		B3417-552-000	Spring		ヒザ上ゲリンク腕バネ	1
20		B3413-227-000	Suspension screw		ヒザ上ゲリンク腕バネ掛ケ軸	1
21		B3416-012-000	Swivel	D.4/79	ツリ棒ダルマ	—
21-1		B3416-555-000	Swivel	A.4/79	ツリ棒ダルマ	1
22		B3418-552-000	Screw	D.4/79	ツリ棒ダルマ止メネジ	—
22-1		B3418-555-000	Screw	A.4/79	ツリ棒ダルマ止メネジ	1
23		RE-0500000-KO	Snap ring		ツリ棒ダルマ止メネジ止メ環	1
24		B3415-552-000	Connecting rod, vertical		ヒザ上ゲ連結棒	1
25		NS-6620310-SP	Nut 3/16-32		ヒザ上ゲ連結棒ナット	1
26		B1509-227-000	Presser spring regulator		押エ調節ネジ	1
27		NS-2820850-SA	Nut 1/2-28	D.4/79	B1511-555-000	—
		B1511-555-000	Nut	A.4/79	押エ調節ネジナット	1
28		B1510-227-000	Presser guide bar		押エ案内棒	1
29	001	B1505-227-000-A	Presser spring		押エ調節バネ	1
30		B1501-127-000	Presser bar		押エ棒	1
31		B1507-552-000	Presser bar guide bracket asm.		押エ棒拘キ (組)	1
32		SS-7111410-SP	Clamp screw 11/64-40 L=14.0		押エ棒拘キ締メネジ	(1)
33		B1521-552-000	Presser bar clamp thread guide		押エ棒拘キ糸案内	1
34		SS-6090650-SP	Screw 9/64-40 L=6.0		押エ棒拘キ糸案内止メネジ	1
35		B1502-541-000	Presser bar bushing, lower		押エ棒下メタル	1
36		SS-8150310-SP	Screw 15/64-28 L=3.4		押エ棒下メタル止メネジ	1
37	001	B1524-012-0A0	Hinged presser foot asm.		自由押エ (組)	1
37-1	001	B1524-012-0B0	Hinged presser foot asm.	A.4/76	自由押エ (組)	1
38		SS-7091110-SP	Screw 9/64-40 L=10.5		自由押エ止メネジ	1
39	001	B1421-522-000	Needle bar guard		針棒安全カバー	1
40	001	B1835-012-000	Bobbin case holder positioning finger		中签押エ	1
41		SS-6111010-SP	Screw 11/64-40 L=9.5		中签押エ止メネジ	1
42		B1837-012-0A0	Bobbin case asm.		ホビンケース (組)	1
43	001	B9117-012-000	Bobbin		ホビン	1
44	001	B1830-127-0A0	Lubricating hook asm.		給油釜 (組)	1
45	001	SS-6110560-TP	Screw		外蓋止メネジ	(2)
46		CS-079106A-SH	Thrust collar asm.		下軸スラスト受ケ (組)	1
47		SS-8110410-TP	Screw 11/64-40 L=3.5		下軸スラスト受ケ止メネジ	(2)
48	001	B1808-552-0A0	Hook driving shaft front screw asm.		下軸前止メネジ (組)	1
49	001	B1809-552-0A0	Oil wick asm.	D.7/75	B1810-552-000	—
	001	B1810-552-000	Oil wick	A.7/75	下軸前止メネジ油心	(1)
50		B1801-412-000	Hook driving shaft		下軸	1
51		B1802-412-0A0	Bushing, front asm.		下軸前メタル (組)	1
52		SS-8151150-SP	Screw 15/64-28 L=10.5		下軸前メタル止メネジ	1
53		B1803-552-000	Bushing, intermediate		下軸中メタル	1
54		B1804-552-B00	Bushing, rear		下軸後メタル	1
55		B1806-038-000	Oil felt	D.6/80	下軸後メタルフェルト	—
55-1		B1806-555-000	Oil felt	A.6/80	下軸後メタルフェルト	1
56		SS-8151550-SP	Screw 15/64-28 L=15.0	D.8/79	SS-8151230-SP	—
		SS-8151230-SP	Screw	A.8/79	下軸後メタル止メネジ	1
57		CS-0791010-SH	Hook driving shaft thrust collar (B) asm.		下軸スラスト受ケ (B) (組)	1
58		SS-8110520-TP	Screw 11/64-40 L=4.5		下軸スラスト受ケ (B) 止メネジ	(2)

Note (注記) 001 Special order part

特別注文部品

001 When these parts are to be used for subclass machines

サブクラスマシン使用の場合、サブクラス専

From the library of: Superior Sewing Machine & Supply LLC

4. FEED MECHANISM COMPONENTS (1)

送り関係 (1)

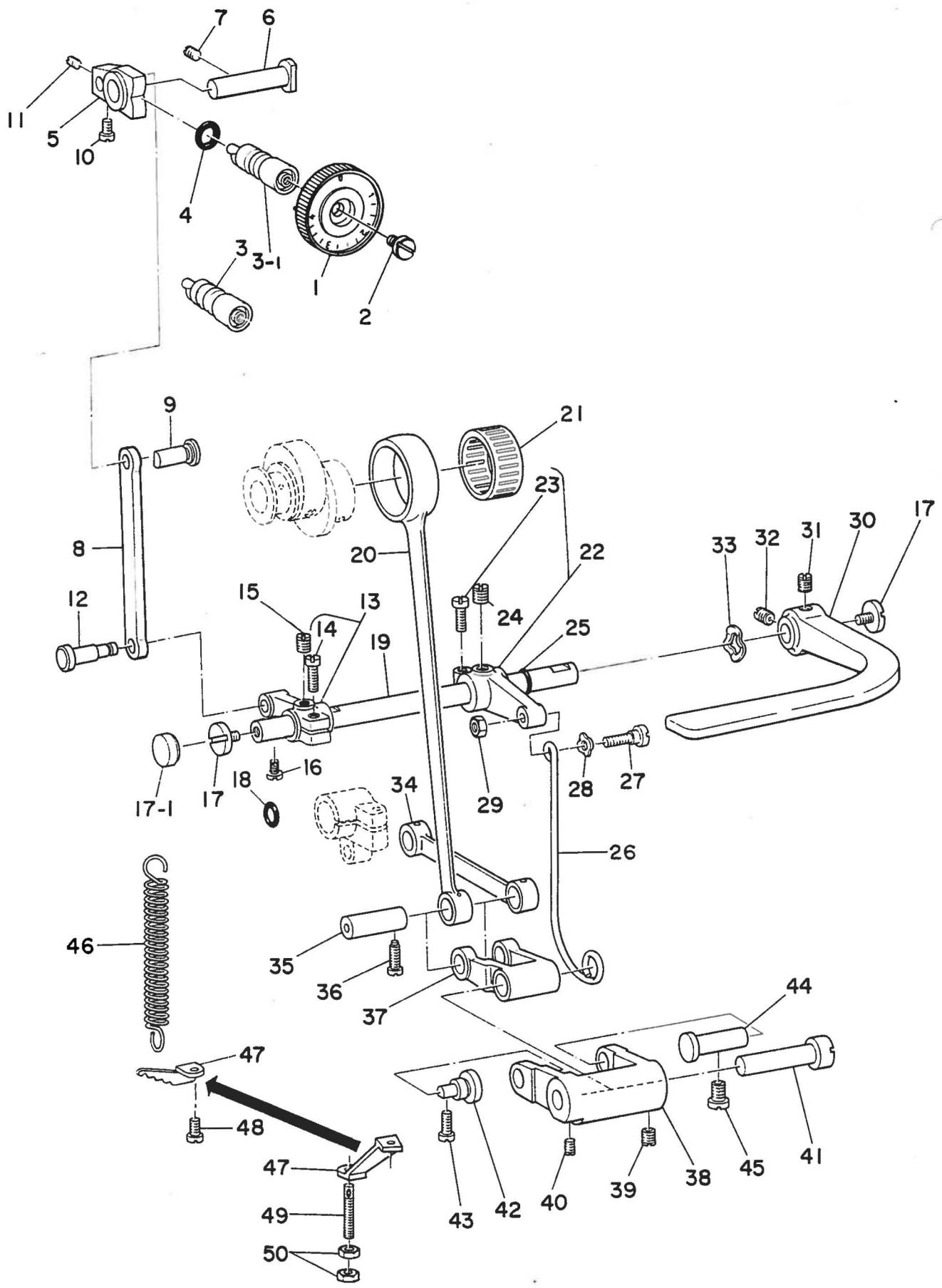

4. FEED MECHANISM COMPONENTS (1)

送り関係 (1)

Ref. No.	Note	Part No.	Description	E.C.	品名	Amt. Req.
	注記	品番		変更年月		数量
1	◆01	B1623-555-0A0-A	Stitch dial asm.	D.4/79	B1623-555-000-A	-
		B1623-555-000-A	Stitch dial asm.	A.4/79	目盛板	1
2		SS-6121050-SP	Screw 3/16-28 L=9.5	D.4/79	SS-6120930-SP	-
		SS-6120930-SP	Screw	A.4/79	目盛板止ネジ	1
3		B1634-555-000-A	Feed regulating screw	D.6/67	送り調節ネジ	1
3-1		B1634-555-000-B	Feed regulating screw	A.6/67	送り調節ネジ	1
4		RO-0742401-00	Rubber ring		送り調節ネジOリング	1
5		B1620-161-000	Feed regulator		送り調節台	1
6		B1622-555-000	Hinge pin		送り調節台止軸	1
7		SS-8151230-SP	Screw 15/64-28 L=12.0	D.12/79	SS-8150710-SP	-
		SS-8150710-SP	Screw	A.12/79	送り調節台止軸止ネジ	1
8		B1625-555-000	Feed regulator connecting rod		送り調節器ロッド	1
9		B1626-555-000	Pin		送り調節器ロッドピン	1
10		SS-7110720-SP	Screw (A) 11/64-40 L=7.0		送り調節器ロッドピン止メネジ (A)	1
11		SS-8110510-SP	Screw (B) 11/64-40 L=5.0		送り調節器ロッドピン止メネジ (B)	1
12		B1628-555-000	Tension spring suspension stud		引張りバネ掛軸	1
13		B1627-555-0A0	Tension spring suspension crank asm.		引張りバネ掛調節器腕 (組)	1
14		SS-6121210-SP	Clamp screw 3/16-28 L=12.0		引張りバネ掛調節器腕締メネジ	(1)
15		SS-8150710-SP	Screw 15/64-28 L=7.0		引張りバネ掛調節器腕止メネジ	1
16		SS-7110910-SP	Screw, 11/64-40 L=8.5		引張りバネ掛軸止メネジ	1
17		SS-7620750-SP	End screw 3/16-32 L=6.5		レバー軸押シネジ	2
17-1		TA-1750502-R0	Rubber plug	A.5/81	送り調節レバー軸穴キャップ	1
18		RO-0611801-00	Rubber ring, small	D.7/82	レバー軸Oリング (小)	-
19		B1621-555-000	Reverse feed control lever shaft	D.5/81	送り調節レバー軸	-
		B1621-555-000-A	Reverse feed control lever shaft	A.5/81	送り調節レバー軸	1
20		B1612-161-000	Feed rocker shaft connecting rod		水平送りロッド	1
21		B1636-581-B00	Needle bearing		水平送りニードルベアリング	1
22		B1629-555-0A0	Control lever crank, rear asm.		送り調節腕 (組)	1
23		SS-6121210-SP	Clamp screw 3/16-28 L=12.0		送り調節腕締メネジ	(1)
24		SS-8150710-SP	Screw 15/64-28 L=7.0		送り調節腕止メネジ	1
25		RO-0691801-00	Rubber ring, large		レバー軸Oリング (大)	1
26		B1630-555-000	Feed driving rocker arm connecting rod		送り調節ロッド	1
27		SD-0500401-SP	Hinge screw D=5.0 H=4.0		送り調節ロッド段ネジ	1
28		WZ-0541510-KP	Washer 5.4 x 9.0 x 0.3		送り調節ロッド座金	1
29		NS-6120310-SP	Nut 3/16-28		送り調節ロッド段ネジナット	1
30		B1624-555-000	Reverse feed control lever		送りレバー	1
31		SS-8660970-TP	Screw (A) 1/4-40 L=8.5		送りレバー止メネジA	1
32		SS-8660810-TP	Screw (B) 1/4-40 L=8.0		送りレバー止メネジB	1
33		WZ-1052010-KP	Waved washer 10.5 x 14.5 x 0.3		送りレバー軸座金	1
34		B1613-555-000	Connecting rod		水平送り連結桿	1
35		B1633-555-000	Feed rocker shaft connecting pin		水平送りロッドピン	1
36		SS-7111260-SP	Screw 11/64-40 L=12.0		水平送りロッドピン止メネジ	1
37		B1614-555-000	Feed driving rocker arm		送り調節二又リンク	1
38		B1617-555-000	Feed driving rocker		送り調節リンク	1
39		SS-8150710-SP	Screw (A) 15/64-28 L=7.0	D.2/79	送り調節二又リンク止メネジ (A)	-
40		SS-8620610-SP	Screw 3/16-32 L=6.0	M.2/79	送り調節二又リンク止メネジ	2
41		B1615-555-000	Hinge pin		送り調節二又リンクピン	1
42		B1619-555-000	Hinge stud		送り調節リンク支エピン	1
43		SS-7111120-SP	Screw 11/64-40 L=10.5		送り調節リンク支エピン止メネジ	1
44		B1618-161-000	Feed driving rocker arm hinge pin		送り調節リンクピン	1
45		SS-7151120-SP	Screw 15/64-28 L=11.0		送り調節リンクピン止メネジ	1
46		B1646-555-000	Tension spring		引張りバネ	1
47		B1632-555-000	Suspension bracket	D.8/82	B1636-555-000	-
		B1636-555-000	Suspension bracket	A.8/82	引張りバネ掛ケ	1
48		SS-7111120-SP	Screw 11/64-40 L=10.5		引張りバネ掛止メネジ	1
49		B1649-161-000	Adjusting screw	D.8/82	引張りバネ調節ネジ	-
50		NS-6110420-SP	Nut 11/64-40	D.8/82	引張りバネ調節ネジナット	-

Note (注記) ◆01 When these parts are to be used for subclass machines of DDL-555, please refer to the exclusive subclass list of DDL-555. (Page 13)

サブクラスミシン使用の場合、サブクラス専用部品一覧表を参照してください。(13ページ)

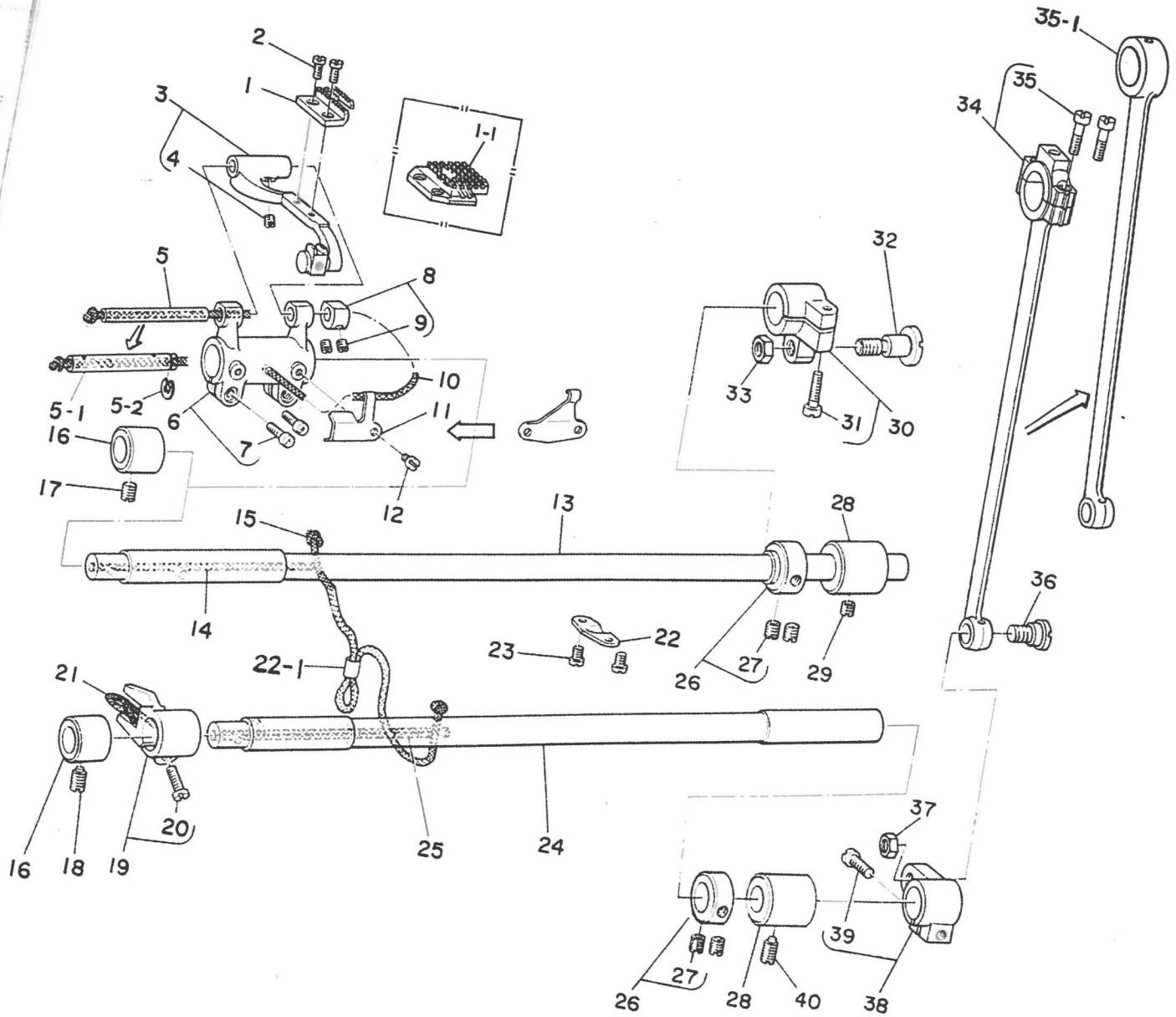

5. FEED MECHANISM COMPONENTS (2)

送り関係 (2)

Ref. No.	Note	Part No.	Description	E.C.	品名	Amt. Req.
	注記	品番		変更年月		数量
1	◆01	B1613-012-A00	Feed dog (A)		送り (A)	1
1-1	◇01	B1613-555-J00	Feed dog (J)	A.8/77	送り (J)	1
2		SS-4080620-TP	... Screw 1/8-44 L=6.4		送り止メネジ	2
3		B1602-155-0B0	Feed bar asm.		送り台 (組)	1
4		SS-8620610-TP	... Shaft clamp screw 3/16-32 L=6.0		送り台軸締メネジ	(1)
5		B1604-012-000	... Shaft	D.2/80	送り台軸	-
5-1		B1604-012-000-A	... Shaft	A.2/80	送り台軸	1
5-2		RE-0500711-KP	... Snap ring	A.2/80	送り台軸止メ輪	1
6		B1603-155-0A0	Feed rocker asm.		送り台腕 (組)	1
7		SS-7111310-TP	... Clamp screw 11/64-40 L=12.8		送り台腕締メネジ	(2)
8		CS-0640860-SH	Thrust collar asm.	D.4/80	送り台軸スラスト受ケ (組)	-
9		SS-8110510-SP	... Screw 11/64-40 L=5.0	D.4/80	送り台軸スラスト受ケ止メネジ	-
10		CQ-3030000-00	Oil wick		送り台腕油心	0.3
11		B1609-155-000	... Holder		送り台腕油心押エ	1
12		SS-6080410-SP	... Screw 1/8-44 L=4.0	M.1/81	送り台腕油心押エ止メネジ	1
13		B1601-552-000	Feed rocker shaft		水平送り軸	1
14		CQ-3030000-00	... Oil wick (A)		水平送り軸油心 (A)	0.3
15		CQ-3030000-00	... Oil wick (B)		水平送り軸油心 (B)	0.5
16		B1604-155-000	Feed rocker shaft bushing, front		送り軸前メタル	2
17		SS-8150710-SP	... Screw 15/64028 L=7.0	D.4/79	SS-8150510-TP	-
		SS-8150510-TP	... Screw	A.4/79	水平送り軸前メタル止メネジ	1
18		SS-8151550-SP	Screw 15/64-28 L=7.0	D.4/79	SS-8151230-SP	-
		SS-8151230-SP	... Screw	A.4/79	上下送り軸前メタル止メネジ	1
19		B1704-155-0A0	Feed rocker shaft crank asm.		上下送りニ又 (組)	1
20		SS-7111120-SP	... Clamp screw 11/64-40 L=10.5		上下送りニ又締メネジ	(1)
21		CQ-2020000-00	Oil wick		上下送り角駒用油心	0.1
22		B1635-552-000	... Holder	D.4/79	BP-4000000-00	-
22-1		BP-4000000-00	Vinyl tube	A.4/79	送り軸油心止具	0.01
23		SS-7110540-SP	... Screw 11/64-40 L=5.0	D.4/79	送り軸油心押エ止メネジ	-
24		B1701-555-000	Feed driving shaft		上下送り軸	1
25		CQ-3030000-00	... Oil wick (A)		上下送り軸油心 (A)	0.3
26		CS-147121A-SH	... Thrust collar asm.		送り軸スラスト受ケ (組)	2
27		SS-8660610-TP	... Screw 1/4-40 L=6.0		送り軸スラスト受ケ止メネジ	(4)
28		B1702-155-000	... Bushing, rear		送り軸後メタル	2
29		SS-8150410-SP	... Screw 15/64-28 L=4.0	D.4/79	SS-8150510-TP	-
		SS-8150510-TP	... Screw	A.4/79	水平送り軸後メタル止メネジ	1
30		B1608-161-0A0	Feed rocker shaft crank, rear asm.		水平送り腕 (組)	1
31		SS-6121610-TP	... Clamp screw 3/16-28 L=15.5		水平送り腕締メネジ	(1)
32		SD-1020701-SP	... Hinge screw D=10.2 H=7.0		水平送り腕段ネジ	1
33		NS-6680410-SP	... Nut 9/32-28		水平送り腕段ネジナット	1
34		B1708-555-0A0	Feed driving shaft connecting rod asm.	D.3/80	上下送りロッド (組)	-
35		SS-6121610-SP	... Clamp screw 3/16-28 L=15.5	D.3/80	上下送りロッドフタ締メネジ	-
35-1		B1708-555-000-A	Feed driving shaft connecting rod	A.3/80	上下送りロッド	1
36		SD-1020701-SP	... Hinge screw D=10.2 H=7.0		上下送りロッド段ネジ	1
37		NS-6680410-SP	... Nut 9/32-28		上下送りロッド段ネジナット	1
38		B1703-155-0A0	Feed driving shaft crank, rear asm.		上下送り腕 (組)	1
39		SS-6121610-TP	... Clamp screw 3/16-28 L=15.5		上下送り腕締メネジ	(1)
40		SS-8150710-SP	Screw, 15/64-28 L=7.0	D.4/79	SS-8150510-TP	-
		SS-8150510-TP	Screw	A.4/79	上下送り軸後メタル止メネジ	1

Note (注記) ◆01 When these parts are to be used for subclass machines of DDL-555, please refer to the exclusive subclass list of DDL-555. (Page 13)

◇01 Special order part

サブクラスマシン使用の場合、サブクラス専用部品一覧表を参照してください。(13ページ)

特別注文部品

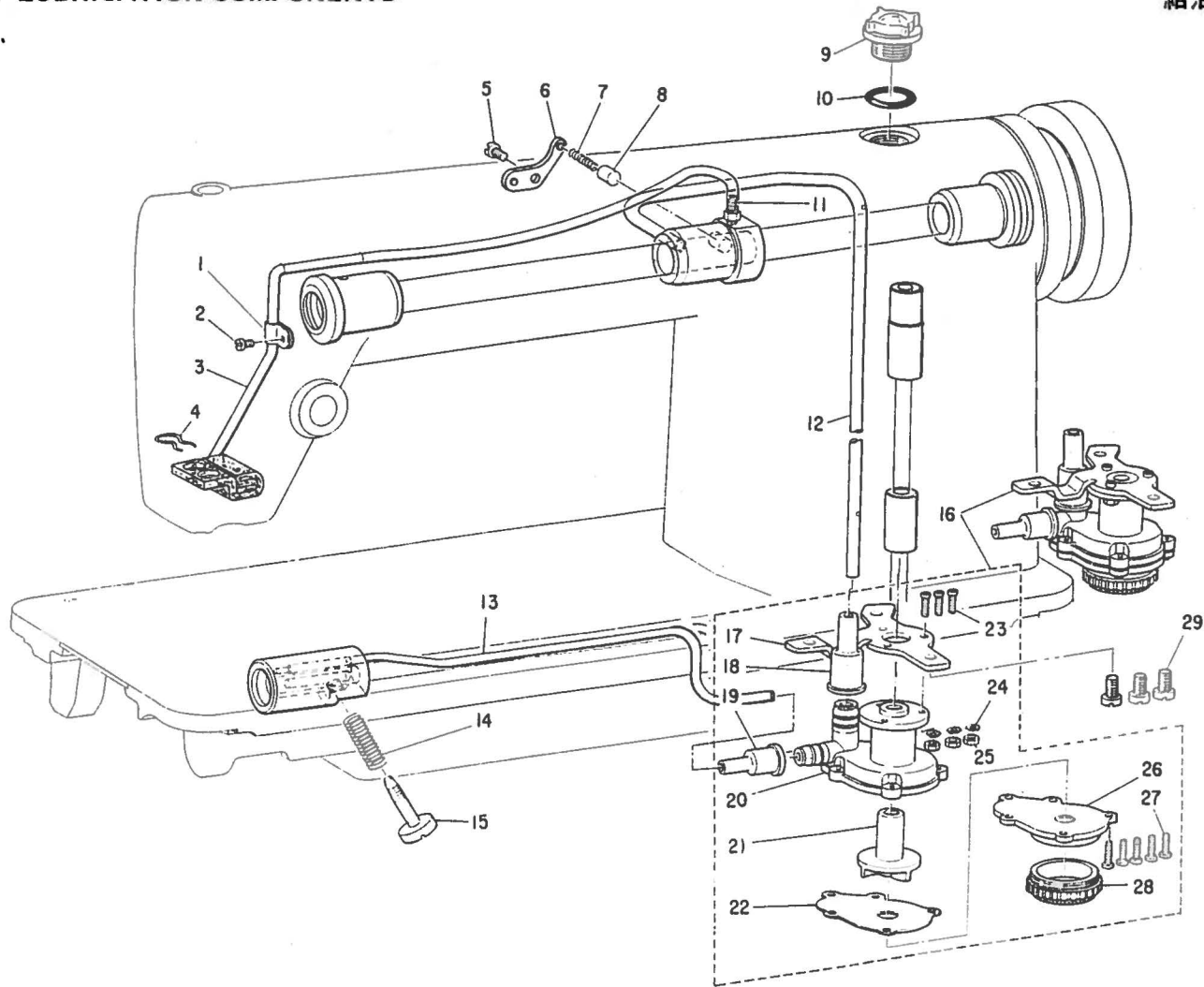

Ref. No.	Note	Part No.	Description	E.C.	Amt. Req.
注記	品番			変更年月	数量
1		B3536-122-000	Oil return tube holder		1
2		SS-7110710-SP	Screw 11/64-40 L=7		1
3		B3526-552-0A0	Oil return tube asm.		1
4		B3529-226-000	Oil felt presser		1
5		SS-7110910-SP	Screw 11/64-40 L=8.5	D.10/80	—
		SS-7110710-SP	Screw 11/64-40 L=7	A.10/80	—
6		B3524-552-000	Plunger thrust plate		1
7		B1214-038-000	Plunger spring		1
8		B3534-155-000	Oil return pump plunger		1
9		B3530-555-000	Oil sight window		1
10		RO-1952401-00	Rubber ring		1
11		SQ-1110402-MZ	Connecting screw		1
12		B3513-227-000-A	Main shaft oil tube		1
13		B3521-555-000	Oil tube		1
14		B2616-372-000	Spring		1
15		B3514-412-000	Oil adjusting screw		1
16		B3501-555-0A0	Lubricating oil pump asm.		1
17		B3503-555-000	Oil pump installing base		(1)
18		B3505-555-000	Rubber joint		(1)
19		B3506-555-000	Rubber joint		(1)
20		B3501-555-000	Lubricating oil pump		(1)
21		B3507-555-000	Oil pump impeller		(1)
22		B3508-555-000	Oil pump impeller cover		(1)
23		SM-4031001-SC	Screw M3x0.5 L=10		(1)
24		WT-0320002-KZ	Washer		(3)
25		NM-6030000-0E	Nut M3x0.5		(3)
26		B3502-555-000	Lubricating oil pump cover		(3)
27		SE-4301031-SR	Screw		(5)
28		B3504-555-000	Filter		(1)
29		SS-6120930-SP	Screw 3/16-28 L=9	D.12/81	—
		SS-6120940-SP	Screw 3/16-28 L=9	A.12/81	—
					3

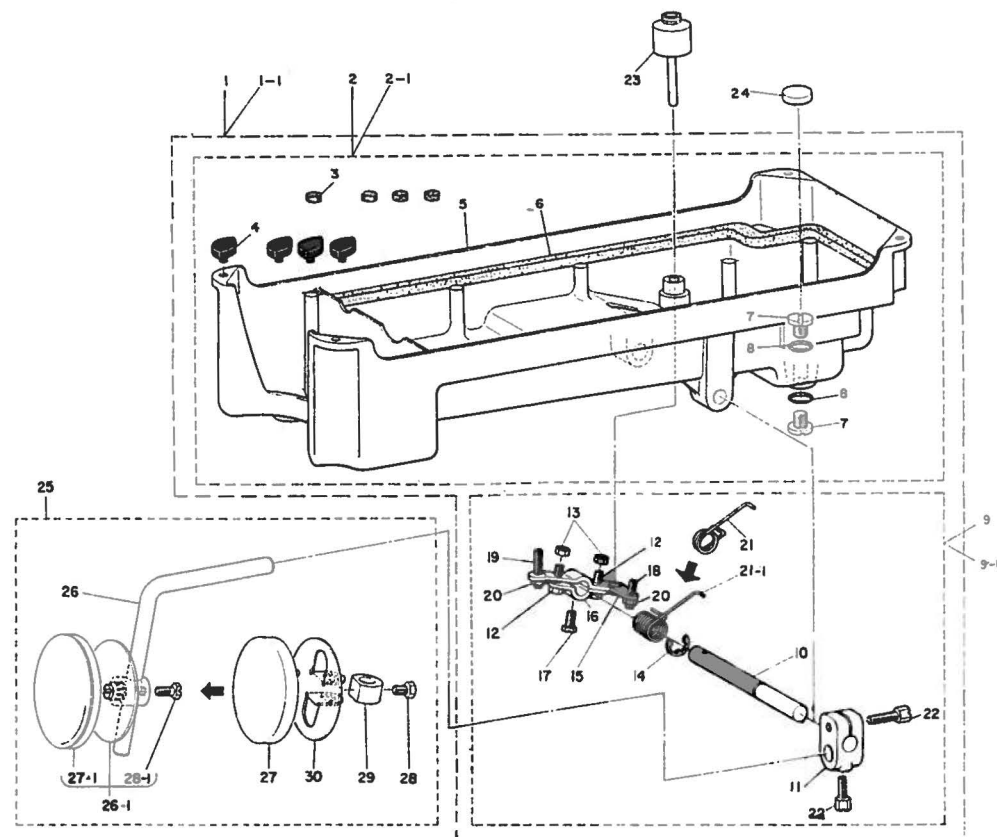

Ref. No.	Note	Part No.	Description	E.C.	品名	Amt. Req.
	注記	品番		変更年月		数量
1		B8217-552-0C0	Oil reservoir asm.	D.7/82	油溜 (組)	-
1-1		D8217-555-ED0	Oil reservoir asm.	A.7/82	油溜 (組)	1
2		B8217-552-0A0	Oil reservoir asm.	D.7/82	油溜 (組)	-
2-1		D8217-555-EB0	Oil reservoir asm.	A.7/82	油溜 (組)	(1)
3		B8227-125-000	Felt cushion	D.7/82	頭部クッション	-
4		B8226-125-000	Rubber cushion	D.7/82	D8227-555-E00	-
		D8227-555-E00	Rubber cushion	A.7/82	頭部支エゴム	(1)
5		B8217-552-000	Oil reservoir		油溜	(1)
6		B8218-552-000	Gasket		油溜パッキン	(1)
7		SS-6741010-SP	Screw 3/8-28 L=10.0	D.7/82	排油穴フタネジ	-
		SS-7701010-SP	Screw 5/16-24 L=10	A.7/82	排油穴フタネジ	(2)
8		B8219-125-000	Oil drain cap gasket	D.7/82	排油穴フタパッキン	-
		RO-0681901-00	Rubber ring	A.7/82	Oリング	(2)
9		B3420-552-0A0	Knee press rod asm.	D.1/77	ヒザ上げ横軸 (組)	(1)
9-1		B3420-552-0A0-A	Knee press rod asm.	A.1/77	ヒザ上げ横軸 (組)	(1)
10		B3420-552-000	Knee press rod		ヒザ当横軸	(1)
11		B3427-122-000	Bearing bracket		ヒザ当立軸取付腕	(1)
12		SS-9151540-SR	Rotating lever clamp screw 15/64-28 L=15.0		ヒザ上げ回転腕締メネジ	(2)
13		NS-6150430-SR	Nut 15/64-28		ヒザ上げ回転腕締メネジナット	(2)
14		B3426-552-000	Thrust ring		ヒザ当横軸スラスト受け	(1)
15		B3425-552-000	Lifting (B)		ヒザ上げ回転腕 (B)	(1)
16		B3424-552-000	Lifting (A)		ヒザ上げ回転腕 (A)	(1)
17		SS-9151220-SR	Screw 15/64-28 L=12.0		ヒザ上げ回転腕止メネジ	(1)
18		SS-8152080-SR	Positioning screw (B) 15/64-28 L=19.5		ヒザ上げ回転腕調節ネジ (B)	(1)
19		SS-8153010-SR	Positioning screw (A) 15/64-28 L=30.0		ヒザ上げ回転腕調節ネジ (A)	(1)
20		NS-6150430-SR	Nut 15/64-28		ヒザ上げ回転腕調節ネジナット	(2)
21		B3429-552-000	Spring	D.1/77	ヒザ上げ回転腕バネ	(1)
21-1		B3429-552-000-A	Spring	A.1/77	ヒザ上げ回転腕バネ	(1)
22		SS-9182010-SN	Clamp screw 9/32-20 L=20.0		ヒザ上げ立軸取付腕締メネジ	(2)
23		B3421-552-0A0	Knee press lifter rod asm.	D.12/78	B3421-555-000	-
		B3421-555-000	Knee press lifter rod	A.12/78	ヒザ上げ押し棒	1
24		B8228-125-000	Oil reservoir magnet		油溜磁石	1
25		B3419-552-0A0	Knee lifter plate rod asm.		ヒザ当立軸 (組)	1
26		B3419-122-000	Knee lifter plate rod		ヒザ当立軸	(1)
26-1		B3430-552-0A0	Knee press plate asm.	A.1/77	ヒザ当板 (組)	(1)
27		B3431-552-000	Knee press plate cover	D.1/77	ヒザ当板カバー	-
27-1		B3431-552-000-A	Knee press plate cover	A.1/77	ヒザ当板カバー	(1)
28		SM-9061003-SE	Stopper screw M6 L=10.0	D.1/77	ヒザ当板ストッパー止メネジ	-
28-1		SS-9661120-CP	Screw 1/4-40 L=10.5	A.1/77	ヒザ当板止メネジ	(1)
29		B3432-552-000	Knee press plate stopper	D.1/77	ヒザ当板ストッパー	-
30		B3430-552-000	Knee press plate	D.1/77	ヒザ当板	-

	Description	DDL-555 Standard 標準	DDL-555-A For light weight materials 薄物用	DDL-555-W For P.P. P.P用	DDL-555-H For heavy weight materials 厚物用	品名
1	Throat plate	B1109-012-A00	B1109-012-i00	D1109-155-W00	B1109-555-H0B	針棒クランク
2	Needle thread guide pin asm.	B1113-155-0A0	D1113-126-WA0	D1113-126-WA0	B1114-012-000	針棒
3	Frame thread guide (A)	B1126-552-000	*	*	B1126-553-000	針棒下メタル
4	Counterweight asm.	B1206-552-0A0	*	*	B1206-553-0A0	針棒糸掛
5	Needle bar crank	B1209-552-000	B1209-552-A00	B1209-552-A00	B1209-553-000	針板
6	Needle bar	B1401-552-A00	B1401-552-D00-A	B1401-552-D00-A	B1401-552-i00	糸案内棒 (組)
7	Needle bar bushing, lower	B1403-155-000	*	*	B1403-553-000	アーム糸案内 (A)
8	Needle bar thread guide	B1418-541-000	B1418-552-B00	B1418-552-B00	—	釣合錠 (組)
9	Needle bar thread guide	B1419-155-000	B1419-553-000	B1419-553-000	B1419-553-000	針棒糸案内
10	Presser spring	B1505-227-000-A	*	*	B1505-552-000-A	押エ調節バネ
11	Hand lifter cam asm.	B1518-481-0A0	B1518-552-AA0-A	B1518-552-AA0-A	*	押エ上ゲカム (組)
12	Hinged presser foot asm.	B1524-012-0A0	B1524-012-0A0	D1524-126-WA0	B1511-543-BA0	自由押エ (組)
12-1	Hinged presser foot asm.	B1524-012-0B0	*	D1524-126-WB0	B1511-543-BB0	自由押エ (組)
13	Feed dog	B1613-012-A00	B1613-012-i00	B1613-155-W00	B1613-555-H00	送り
14	Stitch dial asm.	B1623-555-0A0-A	*	*	B1623-555-HA0-A	目盛板 (組)
15	Lubricating hook asm.	B1830-127-0A0	*	*	B1830-555-HA0	給油蓋 (組)
16	Bobbin case holder	B1835-012-000	*	*	B1835-555-H00	中蓋押エ
17	Thread tension post socket	B3111-552-B00	B3111-126-000	B3111-126-000	*	糸調子棒台
18	Thread tension spring	B3129-012-A00	B3121-352-000	B3121-352-000	B3114-232-000	糸調子バネ
19	Take-up spring	B3128-012-000	B3128-027-000	B3128-027-000	*	糸取りバネ
20	Bobbin	B9117-012-000	B9117-552-A00	B9117-552-A00	*	ポビン
21	Needle	MDB-100B1400	MDA-100B0900	MDA-100B1100	MDB-100B2200	針
22	Arm oil shield screw	SS-6080410-SP	*	*	SS-6080320-SP	面部油防板止メネジ
23	Lower shaft front screw asm.	B1808-552-0A0	*	*	B1808-227-HA0	下軸前止メネジ (組)
24	Feed drive eccentric cam	B1610-555-000-A	*	*	B1610-555-H00-A	送り偏心カム

Note (注記) Parts marked with * are same as standard parts * 標準部品と共通に使用する
 - Parts to be removed - 取り除く部品
 Presser foot asm. of 12-1 is special order parts. 12-1の自由押エ(組)は特別注文部品です

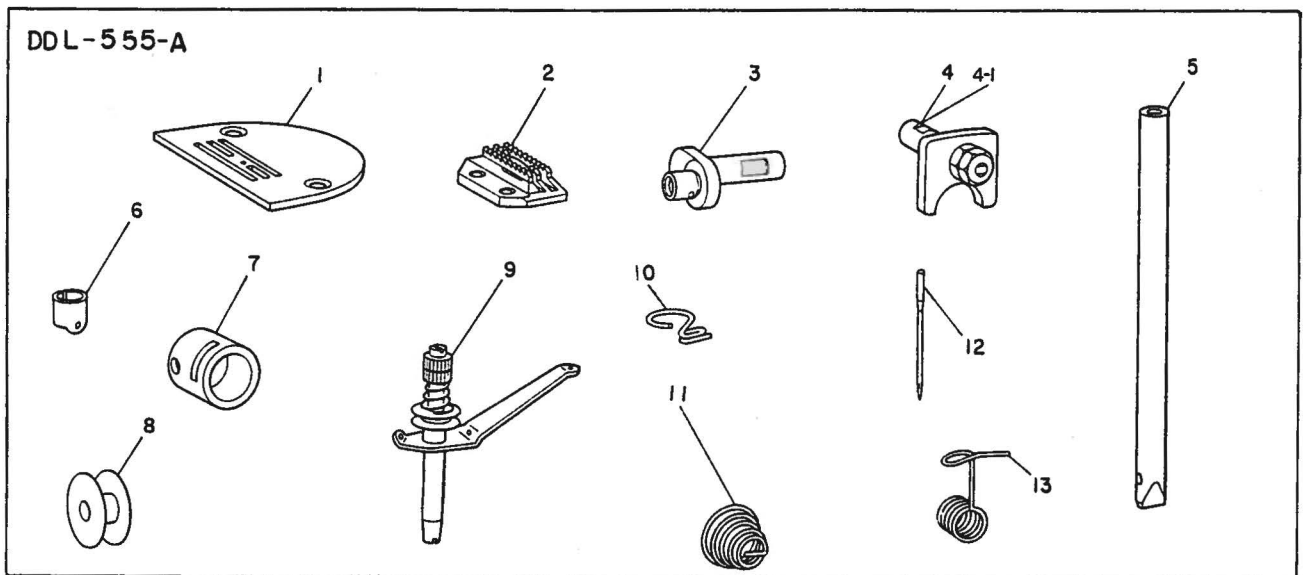

8. EXCLUSIVE PARTS FOR SUBCLASS COMPONENTS

サブクラス専用部品

1. DDL-555-A (FOR LIGHT WEIGHT MATERIALS) (薄物用)

Ref. No.	Note	Part No.	Description	E.C.	品名	Amt. Req.
	注記	品番		変更年月		数量
1		B1109-012-i00	Throat plate (i)		針板 (i)	1
2		B1613-012-i00	Feed dog (i)		送り (i)	1
3		B1209-552-A00	Needle bar crank		針棒クランク	1
4		B1518-552-AA0	Hand lifter cam asm.	D.11/76	押エ上ゲカム (組)	—
4-1		B1518-552-AA0-A	Hand lifter cam asm.	A.11/76	押エ	1
5		B1401-552-D00-A	Needle bar (D)		針棒 (D)	1
6		B1418-552-B00	Needle bar thread guide		針棒糸掛ケ	1
7		B3111-126-000	Thread tension post socket		糸調子棒台	1
8		B9117-552-A00	Bobbin		ポビン	1
9		D1113-126-WA0	Needle thread guide pin asm.		糸案内棒 (組)	1
10		B1419-553-000	Needle bar thread guide		針棒糸案内	1
11		B3121-352-000	Thread tension spring		糸調子バネ	1
12		MDA-100B0900	Needle (DAX1 #9)		針 (DAX1 #9)	1
13		B3128-027-000	Take-up spring		糸取りバネ	1

From the library of: Superior Sewing Machine & Supply LLC

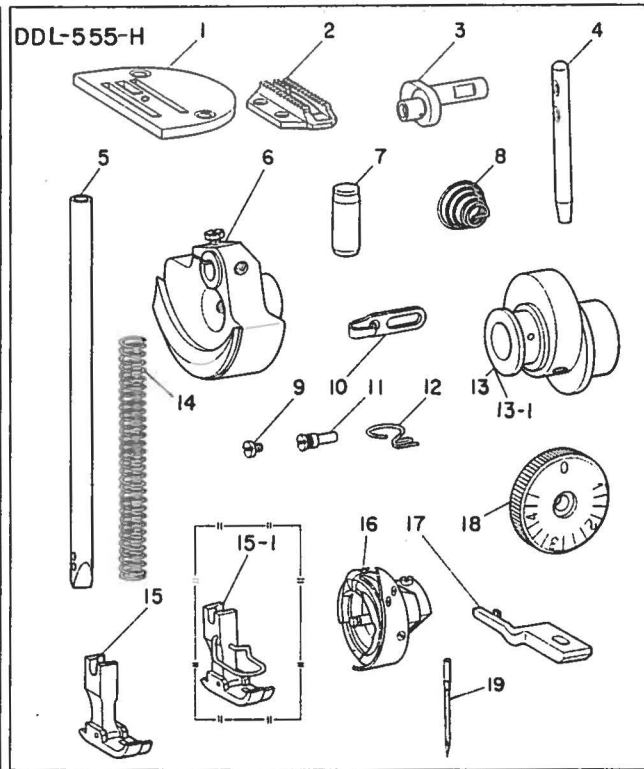
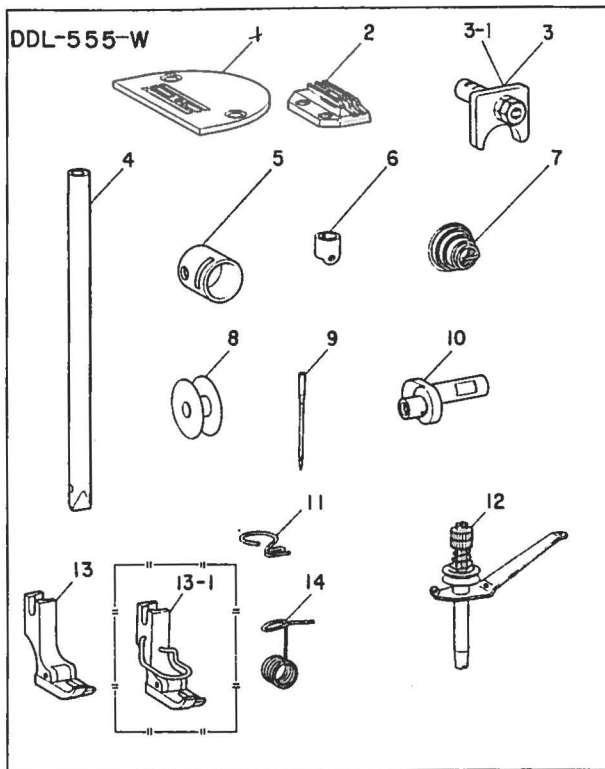

2. DDL-555-W (FOR P.P.) (P.P用)

Ref. No.	Note	Part No.	Description	E.C.	Amt. Req.
	注記	品番		変更年月	数量
1		D1109-155-W00	Throat plate (W)		1
2		D1613-155-W00	Feed dog (W)		1
3		B1518-552-AA0	Hand lifter cam asm.	D.11/76	1
3-1		B1518-552-AA0-A	Hand lifter cam asm.	A.11/76	1
4		B1401-552-D00-A	Needle bar		1
5		B3111-126-000	Thread tension post socket		1
6		B1418-552-B00	Needle bar thread guide		1
7		B3121-352-000	Thread tension spring		1
8		B9117-552-A00	Bobbin		1
9		MDA-100B1100	Needle (DAx1 =11)		1
10		B1209-552-A00	Needle bar crank		1
11		B1419-553-000	Needle bar thread guide		1
12		D1113-126-WA0	Needle thread guide pin asm.		1
13		D1524-126-WA0	Teflon presser foot asm.		1
13-1	01	D1524-126-WB0	Teflon presser foot asm.	A.4/76	1
14		B3128-027-000	Take-up spring		1

3. DDL-555-H (FOR HEAVY WEIGHT MATERIALS) (厚物用)

1		B1109-555-H0B	Throat plate (H)		1
2		B1613-555-H00	Feed dog (H)		1
3		B1209-553-000	Needle bar crank		1
4		B1114-012-000	Needle thread guide pin		1
5		B1401-552-100	Needle bar		1
6		B1206-553-0A0	Counterweight asm.		1
7		B1403-553-000	Needle bar bushing, lower		1
8		B3114-232-000	Thread tension spring		1
9		SS-6080320-SP	Arm oil shield screw 1/8-44 L=2.5		1
10		B1126-553-000	Frame thread guide (A)		1
11		B1808-227-HA0	Hook driving shaft front screw asm.		1
12		B1419-553-000	Needle bar thread guide		1
13		B1610-555-H00	Feed drive eccentric cam	D.3/80	1
13-1		B1610-555-H00-A	Feed drive eccentric cam	A.3/80	1
14		B1505-552-000-A	Presser spring		1
15		B1511-543-BA0	Hinged presser foot asm.		1
15-1	01	B1511-543-BB0	Hinged presser foot asm.	A.4/76	1
16		B1830-555-HA0	Lubricating hook asm.		1
17		B1835-555-H00	Bobbin case holder		1
18		B1623-555-HA0-A	Stitch dial asm.		1
19		MDA-100B2200	Needle (DBx1 #22)		1

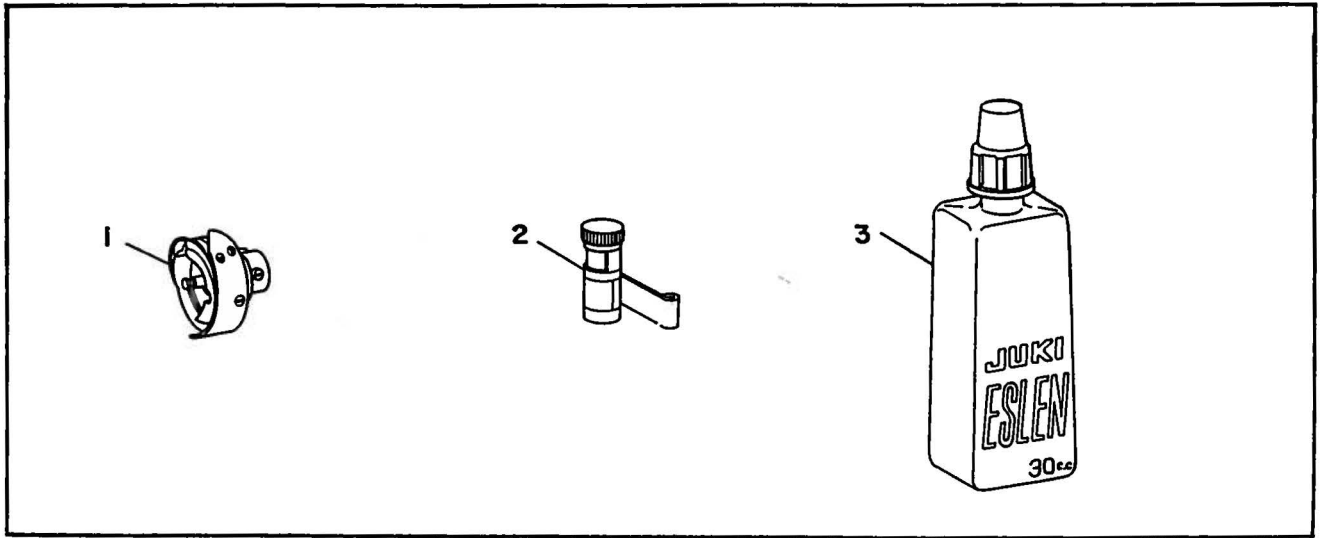

Ref. No.	Note 注記	Part No. 品番	Description	E.C. 変更年月	品名	Amt. Req. 数量
1		B1830-127-TA0	Hook asm. for tricot		トリコット用釜 (組)	1
2		B1130-541-0A0	Silicon oil lubricating unit case asm.		エスレンケース (組)	1
3		B9135-123-0B0	Silicon oil lubricating unit oiler asm. 30cc		エスレン油差シ (組)	1

Part No.	Page	Item	Ref.	Part No.	Page	Item	Ref.	Part No.	Page	Item	Ref.	Part No.	Page	Item	Ref.
品番	頁	項目	No.	品番	頁	項目	No.	品番	頁	項目	No.	品番	頁	項目	No.
CQ-2020000-00	4	2	35	RO-1952401-00	11	6	10	SS-7110540-SP	10	5	23	SS-8151150-SP	4	2	63
CQ-2020000-00	10	5	21	RO-2943101-00	4	2	56	SS-7110710-SP	11	6	2	SS-8151150-SP	4	2	55
CQ-3030000-00	10	5	10					SS-7110710-SP	11	6	5	SS-8151150-SP	6	3	52
CQ-3030000-00	10	5	14	HINGE SCREW			段ネジ	SS-7110720-SP	8	4	10	SS-8151230-SP	6	3	56
CQ-3030000-00	10	5	15	SD-0380552-SL	2	1	12	SS-7110910-SP	2	1	7	SS-8151230-SP	8	4	7
CQ-3030000-00	10	5	25	SD-0500401-SP	8	4	27	SS-7110910-SP	8	4	16	SS-8151230-SP	10	5	18
CQ-3030000-00	10	5	26	SD-0630275-SP	6	3	7	SS-7110910-SP	11	6	5	SS-8151550-SP	4	2	60
				SD-0630301-SP	6	3	8	SS-7111120-SP	2	1	2	SS-8151550-SP	10	5	18
NEEDLE		針		SD-0720331-SP	6	3	18	SS-7111120-SP	8	4	43	SS-8151550-SP	10	5	41
MDA-100B0900	13	8-1	12	SD-1020710-SP	10	5	33	SS-7111120-SP	8	4	48	SS-8152080-SR	12	7	18
MDA-100B1100	14	8-2	9	SD-1020701-SP	10	5	37	SS-7111120-SP	10	5	20	SS-8153010-SR	12	7	19
MDB-100B1000	4	2	24					SS-7111260-SP	8	4	36	SS-8620610-SP	8	4	40
MDB-100B2200	14	8-3	19	CONNECTING SCREW			連結ネジ	SS-7111310-TP	10	5	7	SS-8620610-TP	10	5	4
				SQ-1110402-MZ	11	6	11	SS-7111410-SP	6	3	32	SS-8660610-TP	4	2	34
NUT		ナット						SS-7120910-SP	6	3	10	SS-8660610-TP	4	2	41
NM-6030000-OE	11	6	25	SCREW			ネジ	SS-7151120-SP	4	2	39	SS-8660610-TP	10	5	28
NS-2820850-SA	6	3	27	SE-4301031-SR	11	6	27	SS-7151120-SP	8	4	45	SS-8660810-TP	4	2	53
NS-6060350-SP	2	1	28	SM-4031001-SC	11	6	23	SS-7620750-SP	8	4	17	SS-8660810-TP	8	4	32
NS-6110420-SP	8	4	50	SS-2110920-TP	2	1	43	SS-7681650-TP	4	2	32	SS-8660970-TP	8	4	31
NS-6120310-SP	8	4	29	SS-2110930-SP	4	2	45	SS-7701010-SP	4	2	59	SS-8681950-SP	4	2	31
NS-6150310-SP	2	1	54	SS-4080620-TP	10	5	2	SS-7701010-SP	12	7	7	SS-9151220-SR	12	7	17
NS-6150430-SR	12	7	13	SS-5090610-SP	2	1	26	SS-8090670-SP	2	1	30	SS-9151540-SR	12	7	12
NS-6150430-SR	12	7	20	SS-6060210-SP	2	1	46	SS-8110410-TP	6	3	47	SS-9182010-SN	12	7	22
NS-6620310-SP	6	3	25	SS-6080320-SP	14	8-3	9	SS-8110510-SP	2	1	22	SS-9661120-CP	4	2	30
NS-6680330-SP	10	5	34	SS-6080410-SP	2	1	20	SS-8110510-SP	8	4	11	SS-9661120-CP	12	7	28-1
NS-6680410-SP	10	5	34	SS-6080410-SP	10	5	12	SS-8110510-SP	10	5	9				
NS-6680410-SP	10	5	38	SS-6090650-SP	6	3	34	SS-8110520-TP	4	2	66	RUBBER PLUG			止メ栓
				SS-6090670-TP	4	2	19	SS-8110520-TP	6	3	58	TA-0750704-R0	2	1	13
				SS-6111010-SP	6	3	41	SS-8150310-SP	4	2	16	TA-0750704-R0	2	1	16
PIN		ピン		SS-6110560-TP	6	3	45	SS-8150310-SP	4	2	21	TA-0800704-R0	2	1	13
PS-0200122-K0	11	6	25	SS-6120930-SP	8	4	2	SS-8150310-SP	6	3	36	TA-0800704-R0	2	1	16
RC-1850001-KP	4	2	42-2	SS-6120930-SP	11	6	29	SS-8150410-SP	10	5	30	TA-1050504-R0	2	1	15
				SS-6120940-SP	11	6	29	SS-8150510-TP	10	5	17	TA-1250406-R0	2	1	3
SNAP RING		Eリング		SS-6121210-SP	8	4	14	SS-8150510-TP	10	5	29	TA-1250705-R0	2	1	17-1
RE-0500000-K0	6	3	16	SS-6121210-SP	8	4	23	SS-8150510-TP	10	5	40	TA-1750502-R0	8	4	17-1
RE-0500000-K0	6	3	23	SS-6121050-SP	8	4	2	SS-8150710-SP	2	1	39	TA-2101002-R0	2	1	51
RE-0600000-K0	6	3	4	SS-6121610-SP	10	5	32	SS-8150710-SP	6	3	56	TA-2351004-R0	2	1	52
RUBBER RING		Oリング		SS-6121610-SP	10	5	36	SS-8150710-SP	8	4	7	TA-2351004-R0	2	1	55
RO-0291801-00	4	2	11-2	SS-6121610-TP	10	5	40	SS-8150710-SP	8	4	15				
RO-0371801-00	6	3	13-2	SS-6661110-SP	4	2	43	SS-8150710-SP	8	4	24	WASHER			座金
RO-0442401-00	4	2	33	SS-6741010-SP	12	7	7	SS-8150710-SP	8	4	39	WP-0740516-SP	6	3	12
RO-0611801-00	8	4	18	SS-7080510-SP	4	2	25	SS-8150710-SP	10	5	17				
RO-0681901-00	12	7	8	SS-7080510-TP	4	2	25	SS-8150710-SP	10	5	41	WAVED WASHER			波座金
RO-0691801-00	8	4	25	SS-7091110-SP	6	3	38	SS-8151150-SP	4	2	5	WT-0320002-KZ	11	6	24
RO-0742401-00	8	4	4	SS-7110510-SP	2	1	24	SS-8151150-SP	4	2	37	WZ-0541510-KP	8	4	28
												WZ-1052010-KP	8	4	33

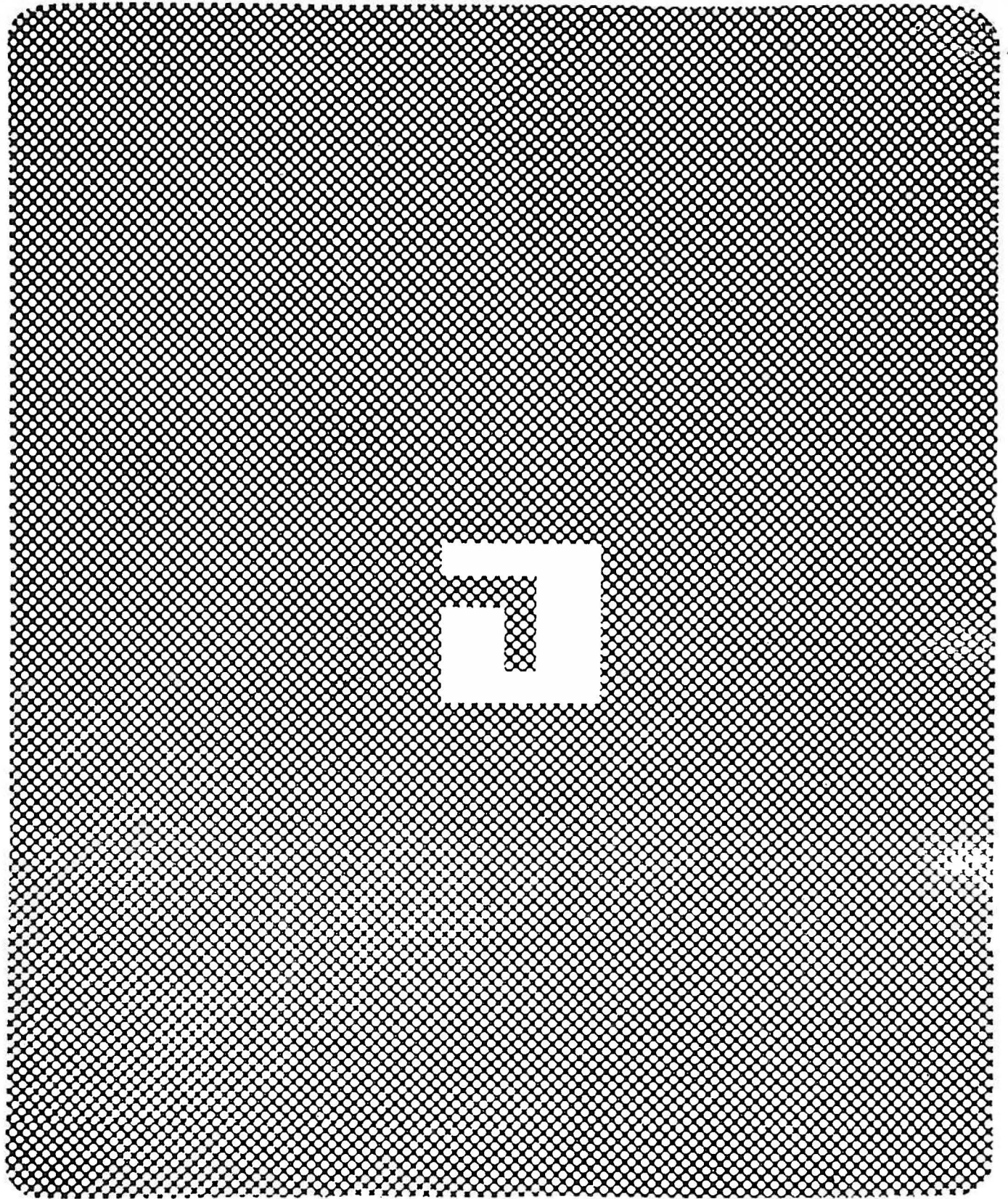

JUKI®
TOKYO JUKI INDUSTRIAL CO., LTD.

Address : 23-3, Kabuki-cho 1-chome, Shinjuku-ku,
Tokyo 160, Japan
Cable : JUKI TOKYO
Telex : 22967, 232-2301
Phone : 03 (205) 1188, 1189, 1190

東京重機工業株式会社

〒182
本社・東京都調布市国領町8の2の1 TEL(480)1111(大代)